

Genesis and Vantage Series Transfer Molding Presses

*Transfer molding presses
for rubber, silicone, epoxy,
plastics and composites*

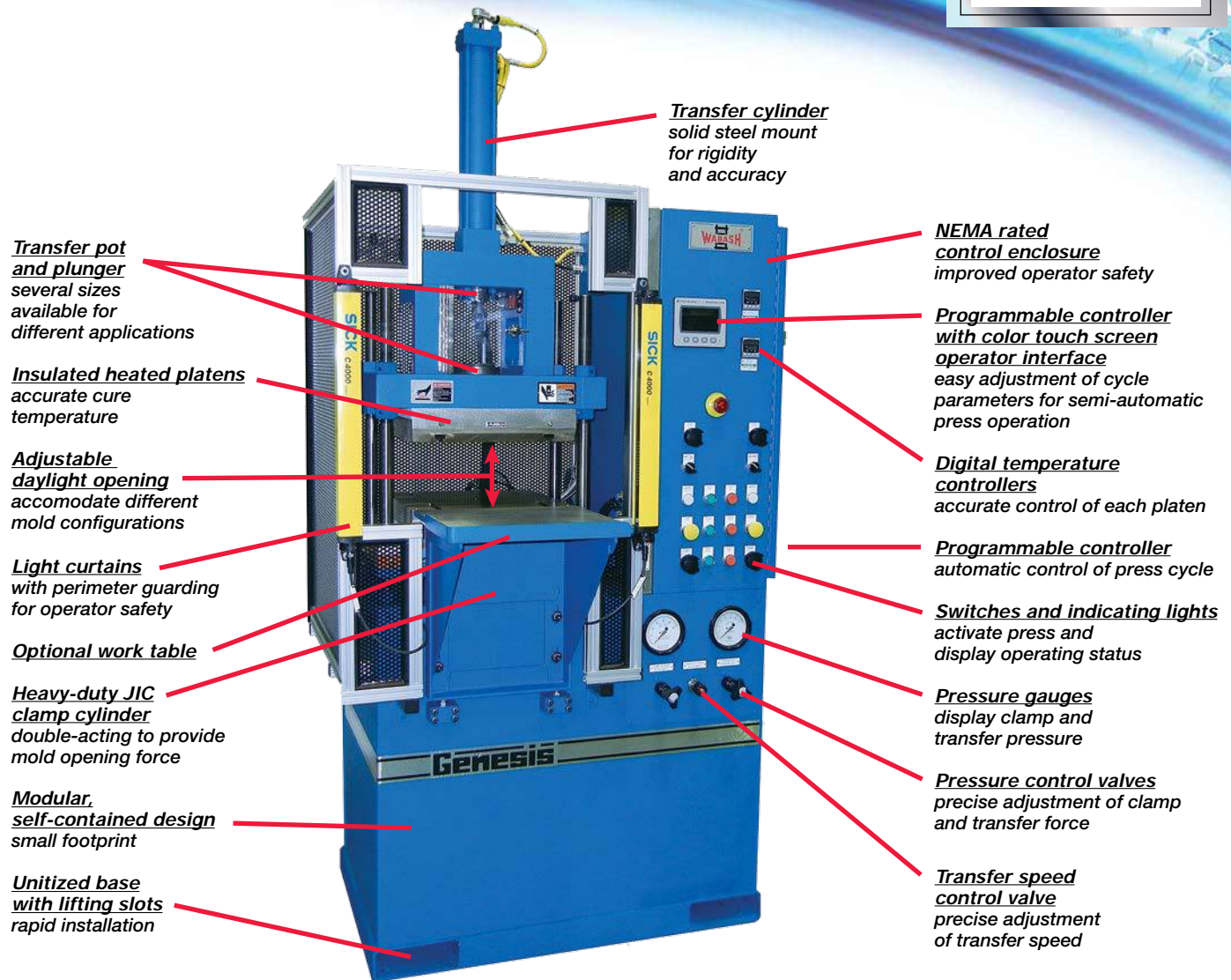

Accurate production of precision parts

Wabash has extended the modular design concept to these versatile presses with a modular transfer unit and a choice of pot and plunger sizes. They are used for precise molding of encapsulated electronics, medical products, "O" rings, insert molded plugs and connectors, spark plugs, rotors, sensors, and many other applications.

Beginning with a Wabash 30-ton Genesis Series or a 50 through 350-ton Vantage Series press, you can configure it to perform your precise task. Transfer molding presses include precision four-post construction for rigidity, and platen level and parallelism. Cartridge heated insulated steel platens

provide precise temperature control of molds for quality results. Individual temperature controllers ensure uniform cure temperatures.

An integral hydraulic system features a variable volume, pressure compensated pump. A flow control valve provides adjustable transfer pressing speed. An optional mold safety circuit is available to protect expensive tooling from damage.

Altogether, the transfer molding presses from Wabash offer a flexible and versatile system for a highly productive press installation.

30 to 350 ton capacities ■ Unlimited flexibility with options



Optional Features:

- High speed hydraulic package
- Air-cooled heat exchanger
- WaterSaver valve for heat exchanger
- Low pressure system
- Clamp pressing speed control
- Adjustable fast close control
- Hydraulic or mechanical part ejector
- Digital display of clamp or transfer force
- Electronic force control
- Pressure and speed profiling of the transfer cylinder
- Fused electrical disconnect
- 7 day timer for heaters
- Alternate safety guarding systems
- Extra heat zones in platens
- Audible or visual alarms
- Temperature controller and plugs for mold heaters
- Mold protection package
- 220, 380 or 575 volt operation
- Mold mounting holes in platen
- Data collection package

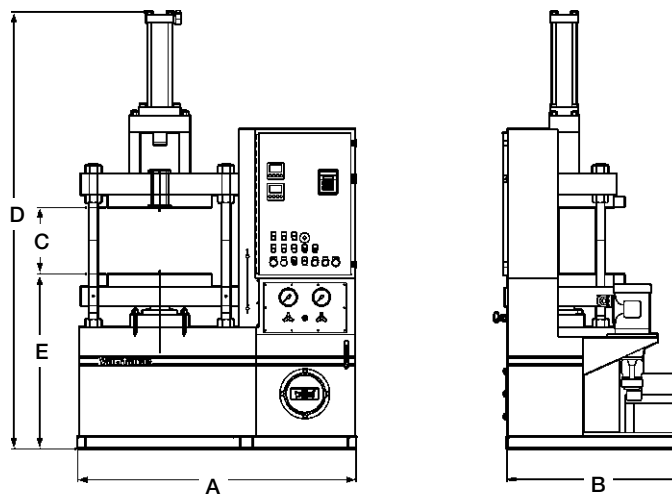

Specifications

Model Number	Clamp Section						Transfer Section						Dimensions (inches)					Horsepower	FLA w/heat @ 460 volt	Weight (lbs)					
	Force (tons)	Platens Size (in)	Heat (kW)	Bore (in)	Stroke (in)	Speed (ipm)	Force (tons)	Cylinder Bore (in)	Stroke (in)	Speed (ipm)	Pot size Dia. (in)	Length (in)	A	B	C (Adj)	D	E								
GENESIS SERIES																									
GT30-12	30	12x12	9.6	5	6	75	5	75	1	7.5	2.5	15	220	20	240	1.5	7	42	51	6-12	95	43	5	18	3,100
GT30-15	30	15x15	13.6	5	6	75	5	75	1	7.5	2.5	15	220	20	240	1.5	7	42	51	6-12	95	43	5	22	3,200
VANTAGE SERIES																									
VT50-15	50	15x15	13.6	7	8	130	10	120	1	15	4	15	225	30	275	2.0	8	61	39	8-16	102	42	7.5	26	4,900
VT50-18	50	18x18	20.8	7	8	130	10	120	1	15	4	15	225	30	275	2.0	8	61	39	8-16	102	42	7.5	33	5,100
VT75-18	75	18x18	20.8	8	8	105	8	105	2	25	5	16	225	30	275	2.5	9	61	39	8-16	105	42	10	36	5,300
VT75-24	75	24x24	30.4	8	8	105	8	105	2	25	5	16	225	30	275	2.5	9	67	39	8-16	105	42	10	46	6,700
VT100-18	100	18x18	20.8	10	12	90	7	80	2	35	6	18	150	30	190	3.0	10	64	39	12-20	110	42	15	43	7,100
VT100-24	100	24x24	30.4	10	12	90	7	80	2	35	6	18	150	30	190	3.0	10	69	39	12-20	110	42	15	53	7,600
VT150-24	150	24x24	30.4	12	12	110	5	90	3	50	7	20	165	20	220	3.5	10	70	39	12-20	120	42	15	53	8,000
VT200-24	200	24x24	30.4	14	12	95	5	70	3	50	7	22	190	20	240	3.5	12	78	45	12-24	126	44	15	53	13,500
VT250-30	250	30x30	45.2	16	12	100	5	65	4	70	8	23	160	20	180	4.0	13	85	48	12-24	132	45	20	74	14,500
VT300-30	300	30x30	45.2	16	16	100	5	65	5	75	8	25	160	20	180	4.0	14	87	48	16-32	136	45	20	74	17,200
VT350-36	350	36x36	61.4	18	16	75	4	65	5	90	9	28	135	20	170	5.0	15	93	54	16-32	140	47	25	93	23,400

As a result of our program of continuous improvement, specifications are subject to change without notice. Consult factory for specific data and pricing.

Rely on Wabash presses for every need

Over the years, Wabash MPI has accepted, and accomplished, the challenge of designing standard and custom presses for industry worldwide. Wabash MPI manufactures presses to meet nearly every production requirement. Parts and service are readily available on all Wabash presses. All are manufactured in the U.S.A. Our customers are accustomed to the reliable performance and low maintenance requirements of their Wabash presses.

That's one of the many reasons they return to Wabash when their business warrants additional machines. We've been building them that way for over 70 years. For more information on any of our presses, see your Wabash MPI representative or visit our website, call or e-mail us.



Clean room application



WABASH MPI

1569 Morris St., P.O. Box 298
 Wabash, IN 46992-0298 U.S.A.
 Phone: 260-563-1184 • Fax: 260-563-1396
 E-mail: wabashmpi@acscorporate.com
 www.wabashmpi.com



ISO 9001:2015 Certified

All new Wabash presses are manufactured in compliance with current regulations and are furnished with safety guards as standard equipment. Guards may have been removed in some photographs for clarity. Wabash strongly recommends use of guards and personal protection equipment when operating any press. As a result of continuous improvement, specifications are subject to change without notice. Consult factory for specific data and pricing.